

1. GENERAL INFORMATION

Consult factory for Class I, II & III locations, installation and application instructions.

Description

The BRITECH PT series of self-regulating parallel circuit heating cables are designed for freeze protection and temperature maintenance of pipes and tanks used for potable or process water, grease lines, product pipelines, fire protection/sprinkler systems.

The BRITECH PT system is easy to design and to install following the provided installation instructions and utilizing the required accessory kits. The heating cable can be cut to length at the job site and installed directly on pipes simplifying the installation process and reducing waste.

Approvals

Certification
CAN/CSA-C22.2 No. 130-03
 1862457; Class: 2878-01, 2878-81
c_{us} Class: 2872-01, 2872-81
Class I, Div. 2, Groups A, B, C, D
Class II, Div. 2 Groups E, F, G
Class III

PT Cable Construction

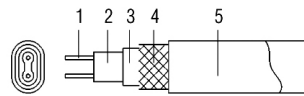

- 1 Conductor
- 2 Heating element
- 3 Insulating sleeve
- 4 Braided Jacket
- 5 Protective outer sleeve

Power Connection Kits

For power connection of the system please refer to the Power Connection and Splice Kit manuals for complete instructions.

BRI-PEK-PT	Power Connection & End Seal Kit
BRI-TSP-1	T-Splice & End Seal Kit

Installation Temperatures

- Minimum installation temperature: -55 °C
- Minimum switched on temperature: -40 °C

Operating Temperatures

- Max. operating temperature switched off max. 190 °C (1000 hours cumulative)
- Max. operating temperature switched on max. 120 °C

Ground Fault Protection:

A ground fault protection device must be used with this heating device. 30mA GFEP protection required. Contact Britech for selection of GFIs and controls.

For Technical Assistance:

For product selection, design assistance and technical questions please contact Britech at 1-877-335-7790

Made in Germany





WARNINGS

This heat tracing system must be installed correctly to ensure proper operation and to prevent shock and fire. Read these important warnings and carefully follow all the installation instructions.

- To comply with Britech (Bartec) requirements, agency certifications and the Canadian Electrical Code and to protect against the risk of fire, ground-fault equipment protection must be used on each heating cable circuit.
- Approvals and performances are based on the use of Britech (Bartec) specified parts only. Do not substitute parts.
- Electricians trained for installation of trace heating shall install the trace heating cable. They shall also ensure orderly condition, operation and monitoring of the operating equipment as well as the implementation of maintenance and repair works.

2. SYSTEM COMPONENTS

Heating Cables

Catalogue number:	PT	X	XX	① Supply voltage: 1-120V, 2-208~240V
	①	②		② Heat output at 10°C, watts/m

PT - 120V

PT110-1560P-120V (3W/ft)
PT115-1560P-120V (5W/ft)
PT120-1560P-120V (6W/ft)
PT125-1560P-120V (8W/ft)
PT135-1560P-120V (11W/ft)
PT145-1560P-120V (14W/ft)
PT160-1560P-120V (18W/ft)

PT - 208V (Adjusted from 240V)

PT210-1560P-208V (2.5W/ft)
PT215-1560P-208V (4W/ft)
PT220-1560P-208V (5W/ft)
PT225-1560P-208V (6.5W/ft)
PT230-1560P-208V (8W/ft)
PT245-1560P-208V (12W/ft)
PT260-1560P-208V (16W/ft)

PT - 240V

PT210-1560P-240V (3W/ft)
PT215-1560P-240V (5W/ft)
PT220-1560P-240V (6W/ft)
PT225-1560P-240V (8W/ft)
PT230-1560P-240V (9W/ft)
PT245-1560P-240V (14W/ft)
PT260-1560P-240V (18W/ft)

Connection Kits

Catalogue No. :	Description	Heating Cable Allowance	Qty Required
BRI-PEK-PT	Power Connection & End Seal Kit	2 ft	1 per power connection/end seal
BRI-TSP-1	T-Splice Kit & End Seal Kit	2 ft	1 per t-splice/end seal

Mounting Accessories

Catalogue No. :	Description	Target Area
6758	3/4" fibreglass tape, 180'/roll	Metal pipes
CT-F4010CW	2" aluminum tape, 150'/roll	PVC pipes

* Note: Adhesives/sticky pads or hardware required to fasten mounting clips to roof or gutter are not included, to be supplied by installer.

Controls

Catalogue No. :	Description	Voltage	# of RTD
BRI-A19-4X20	Weatherproof thermostat	120V-240V	1
TraceMate I	Single circuit heat trace controller	120V-240V	1
TraceMate II	Dual circuit heat trace controller	208V-240V	2
MS-10ADIN2	10-circuit heat trace control panel	120V-240V	10
Custom MasterTrace Panel	Custom engineered control panel	120V-240V	-

3. INSTALLATION

Before installation

- The surface of the pipe must be dry and clean.
- Check the voltage in the power supply. A deviation from the nominal operating voltage will change the heating power and may harm the cable.
- The size of the protective equipment may not be larger than the heating cable specifications and must agree with the length of cable to be installed. Circuit breakers of type C in conformance with the EN 60898 standard are recommended.
- Only carry out the installation at temperatures above the specified minimum installation temperature.
- Before installing any connection to the cable, check the electrical resistance between the bus wires and the braid. It must be at least 20 MΩ for a minimum supply voltage of 500 VDC. The use of 2500 VDC megaohmmeter is recommended.



WARNINGS

De-energise all power circuits before installation or servicing.

Only use connection systems that protect the electrical connection and the cable ends against the penetration of water or moisture.

The metal sheath/braid of this trace heater must be connected to a suitable ground terminal.

Do not splice the bus wires. This would result in a short circuit.

The presence of the trace heaters shall be made evident by the posting of caution signs or markings at appropriate locations and/or at frequent intervals along the circuit.

- This trace heating cable shall be installed by an electrician trained for installation of trace heating.
- Unwind the heating cable from the spool in a straight manner and cut to size. Do not exceed the maximum installation circuit lengths.
- Improper installation or the use of improper components must be avoided to prevent moisture migration which can lead to electrical arcing.
- Any defective cable or component must be replaced as soon as possible.
- All gaskets used for the heat trace connections must be replaced after every disassembly.

Calculation of required power in Watts

To do a calculation for choosing the correct heating cable(s) you need the following data:

- Pipe dimensions, or the surface area of the tank
- Thermal insulation thickness
- The surrounding or ambient temperature
- Desired final temperature of the tank or pipe

Unknown and non-controllable factors require a safety factor to ensure there is enough heat should there be an unplanned or unknown occurrence. A safety margin equal to a factor of 1.2 is not uncommon.

Insulated Pipes

In general pipes installed in air need to be insulated. Without insulation the heat loss will be quite high, even for small pipe diameters. For example, a non-insulated 1" water pipe will have a heat demand of 13.7 W/ft. at -30 °C, while an insulated pipe, with 1" of insulation will require only 2.7 W/ft.

Recommended loads for insulated Pipe (W/ft)

Pipe Diameter (in)	Thickness of Insulation											
	15 mm			25 mm			50 mm			100 mm		
	ΔT			ΔT			ΔT			ΔT		
	10°C	20°C	30°C	10°C	20°C	30°C	10°C	20°C	30°C	10°C	20°C	30°C
0.75	1.1	2.0	3.4	0.8	1.7	2.1	0.6	1.1	1.5	0.5	0.8	1.1
1	1.2	2.4	3.7	0.9	1.8	2.7	0.6	1.2	1.8	0.5	0.9	1.2
1.25	1.5	3.0	4.6	1.2	2.1	3.0	0.8	1.5	2.1	0.6	0.9	1.5
1.5	1.7	3.4	4.9	1.2	2.4	3.4	0.8	1.5	2.1	0.6	1.1	1.5
2	2.0	4.0	5.8	1.5	2.7	4.0	0.9	1.8	2.4	0.6	1.2	1.8
2.5	2.4	4.9	7.3	1.5	3.0	4.6	0.9	1.8	2.7	0.6	1.2	1.8
3	2.7	5.5	8.2	1.8	3.7	5.2	1.2	2.1	3.4	0.8	1.4	2.1
4	3.4	6.7	10.1	2.4	4.6	6.7	1.2	2.4	3.7	0.8	1.5	2.4
5	4.3	8.5	12.8	2.4	5.2	7.6	1.5	3.0	4.6	0.9	1.8	2.7
6	4.6	9.1	13.7	3.0	6.1	9.1	1.8	3.4	5.2	1.1	2.1	3.0
7	5.2	10.4	15.5	3.4	6.7	10.1	1.8	3.7	5.5	1.2	2.4	3.4
8	6.1	12.2	18.0	4.0	7.6	11.3	2.1	4.3	6.4	1.2	2.4	3.7
9	6.7	13.1	19.5	4.3	8.2	12.2	2.4	4.6	7.0	1.4	2.7	4.0
10	7.0	14.0	21.0	4.6	9.1	13.7	2.4	4.9	7.3	1.5	3.0	4.3

ΔT= temperature difference between the surroundings and the inside of the pipe

Determine the length of the cable

The heating circuit length depends on the voltage and the circuit breaker for the power supply and the cut-in temperature of the heating cable. The maximum heating circuit length must be adhered to in conformance with the technical specifications of the corresponding heating cable type.

The following heating cable pieces must be taken into account when determining the correct heating cable length, without exceeding the maximum installation length:

- Add more length (approx. 2 ft) at the beginning and end for the connection and/or the termination.
- Add heating cable to heat valves, holding devices, flanges and other accessories. More heating cable will be needed if it is to be wound around the pipe in spiral form.

In installation in a straight line on the pipe, we recommend an arrangement in the 4 and/or 8 o'clock position. As a basic rule, the heating cable should always be laid straight on the pipe. The heating cable may only be laid in spiral form if expressly prescribed in the project planning.

Typical installation



Example of winding



Cable Orientation

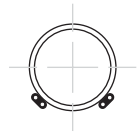

Example of spacing

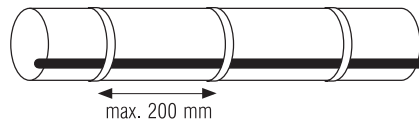

Determine the number of circuits

The circuit length for a given over current protection device shall not exceed the maximum length specified in the following tables. If the total heating cable length exceeds the maximum circuit length for the expected start-up temperature, more than one circuit will be required.

$$\text{Minimum number of circuits} = \frac{\text{Total cable length}}{\text{Maximum recommended circuit length}}$$

Ground-fault protection on each heating cable branch circuit is required by the Canadian Electrical Code to minimize the danger of fire from sustained electrical arcing if the heating cable is damaged or improperly installed.



Procedure for installing heating cable



Always protect heating cable ends from the penetration of water or moisture, particularly when the heating cable is being stored or left for a lengthy time without connections.

1. Unwind the heating cable from the roll in a straight line. Avoid excessive pulling forces and do not bend or squeeze the heating cable. It is recommended to use a roll holder.
2. Begin to attach the heating cable onto the pipe and/or other elements, with due consideration to the following points:
 - a. Additional heating cable lengths for assembling the cable (connection/termination, branches)
 - b. Heating cable loops wherever necessary
 - c. Do not exceed the maximum heating circuit length. Do not cut heating cable until installation and attachment are finished.
3. Mount the connection and/or termination in conformance with the instructions from the manufacturer of the connection systems.



Never connect the heating cable's two live conductors together. This would result in a short circuit. Connect the protective braiding to the earth conductor.

4. Check the electrical resistance between the conductors and the protective braiding (ground) before the thermal insulation is assembled (consult inspection instructions in the section on upkeep).
5. Only mount the thermal insulation if the electrical test has been passed. The thermal insulation should be dry and all connections should be sealed tightly so that no water can penetrate. Take care that none of the thermal insulation fastenings are in contact with the heating cable or can damage it, e.g. screws or terminals.
6. Repeat the test for electrical resistance. This provides evidence that the heating cable was not damaged at assembly.
7. Fill in the installation report. Mark the installation. This makes maintenance easier.

Attaching heating cable to metal pipes

- The flat side of the heating cable should be affixed as flush as possible onto the pipe to ensure effective heat transmission.
- The heating cable should be attached with total surface contact but excessive tension, pressure or twisting must be avoided.
- Use temperature-resistant adhesive tape, e.g. fibreglass tape that has the same or better temperature resistance as the heating cable.

Attaching heating cable to plastic pipes

- When heating plastic pipes, aluminum-adhesive tape or foil should be provided under or under and over the heating cable for better heat transmission and distribution.

Aluminum foil for plastic pipes



Assembly at special parts

Provide additional heating cable loops for valves, flanges, holding devices, pumps and other pipe accessories to ease repairs or replacement of these parts and to reduce the risk of mechanical forces caused by thermal expansion. See example illustrations on the following page.



WARNINGS

- Never use adhesive tapes that contain plasticizers or are made of PVC
- Never use cable ties made of metal or nylon

**Examples
of assembly
at special parts**

On a valve

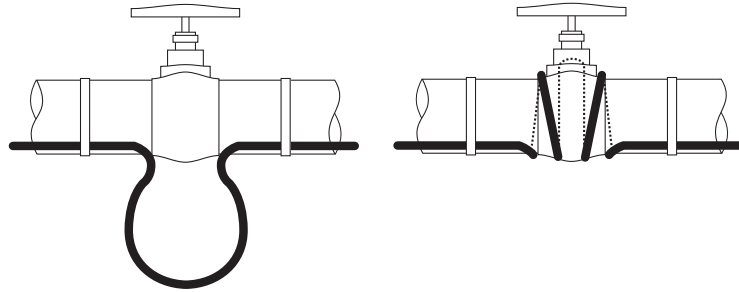

On a flange

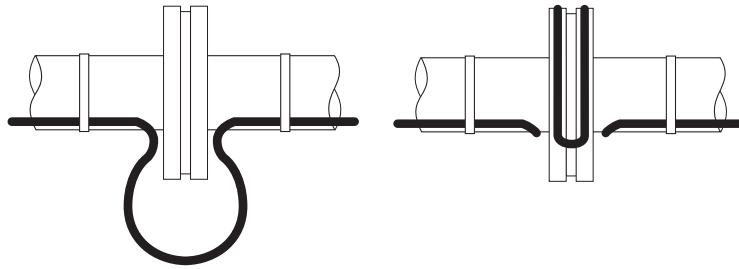

On a pipe bend

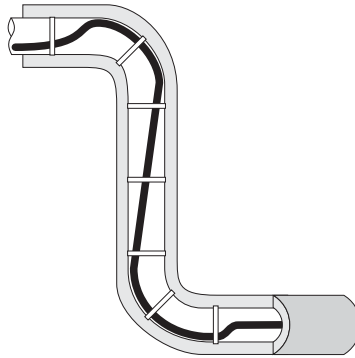

Avoid clamping the heating tape; e.g. between a pipe attachment and the pipe

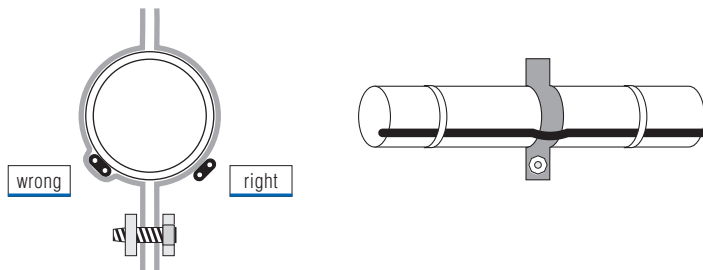

Power connection and splices

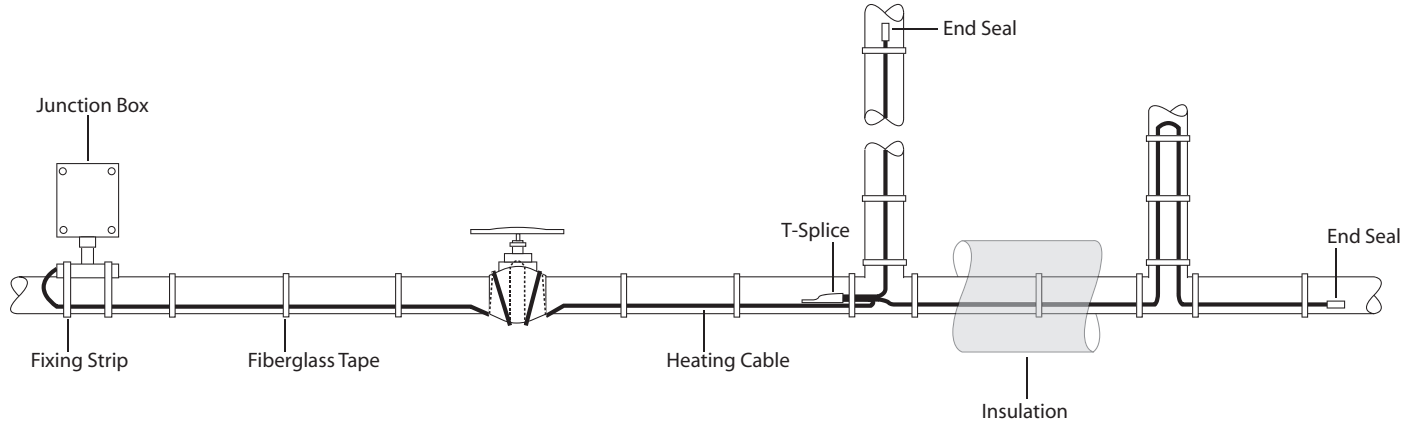

Please refer to Britech's Power Connection and Splice Kit manuals for instructions.

BRI-PEK-PT	Power connection & End seal kit
BRI-TSP-1	T-Splice & End seal kit

Thermostat and controller

Secure thermostat capillary/ RTD sensor to pipe surface with tape or strapping. Capillary bulb/ RTD sensor shall not overlap, touch or cross heating cable.

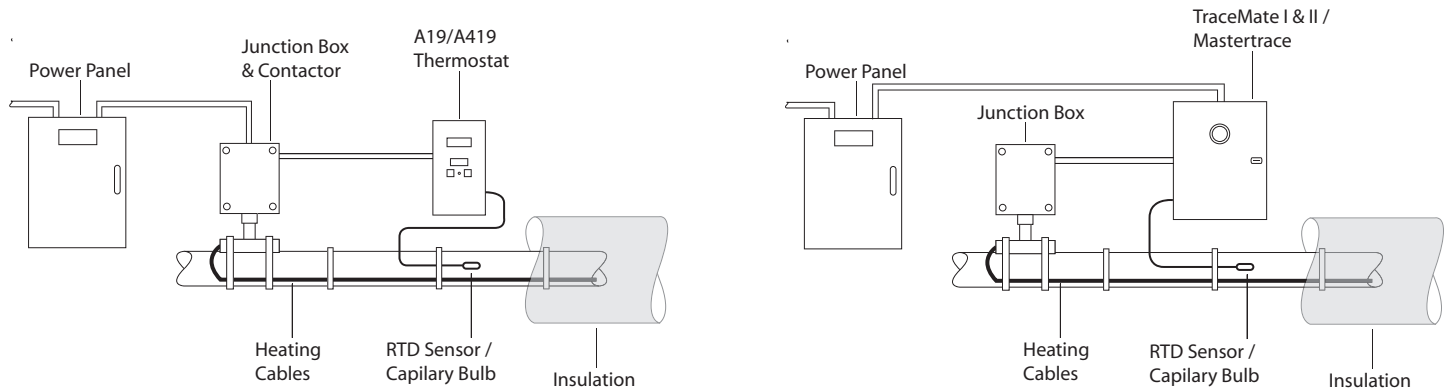

4. OPERATION AND MAINTENANCE



WARNINGS

All applicable safety instructions must be observed prior to the implementation of any maintenance or failure rectification works.

De-energise all power circuits before servicing.

System start-up

HT-1 heat trace caution labels must be visibly located. One must be at the circuit breaker panel, the other on or next to the control device for the cable unit.

When the heating cable installation is complete, visually inspect for mechanical damage and test the entire circuit for insulation resistance prior to applying power. Apply a test voltage of at least 2500 VDC between the heating cable bus wires and the grounding braid. The minimum acceptable reading is 20 MΩ. Record the value.

Power the system with the appropriate voltage. The voltage rating of the heating cable must be suitable for the service being used. A deviation from the nominal operating voltage will change the heating power.

Repair

Defective heating cables should NOT be repaired!

Repairs are not recommended for the following reasons:

- A fault often causes faulty currents, which gradually destroy the contact surface between the conductors and the heating element.
- If the penetration of water is the reason for the fault, there is a possibility that sparks might occur again after the repairs.

Always replace the entire length of a damaged heating cable!

Damaged products

Remove damaged cables and replace the entire section. Defective cable or component must be replaced immediately to avoid moisture migration into the good section of the cable. Replace all gaskets used for the heat trace connections after every disassembly.

Disclaimer of Liability

Any information given here is to be understood as a guideline without any legal obligation. Technical data subject to alteration without notice.

Product Name: _____

Model #: _____ **Watts:** _____ **Volts:** _____

Supplier/Purchased from: _____

APPLICATION: PIPE TRACING ROOF, GUTTER AND DRAINS OTHER: _____

LOCATION : _____

TEST	Prior to applying power to system	After applying power to system	Installation Notes
Test Voltage of Cable (M OHMS)			
Insulation Resistance (M OHMS)			

Address of Installation: _____

Date of Installation: _____ / _____ / _____ (MM/DD/YY)

Name of Qualified Electrician: _____

Signature of Qualified Electrician: _____

IMPORTANT: The system warranty is not valid without evidence that the system resistance has been tested. Control Card must be completed and given to the property or homeowner upon completion of installation and required testing.

For assistance with your heating cable product please contact Britech by calling 1-877-335-7790 or email info@britech.ca

WARRANTY POLICY

All products sold in Canada by Britech Corp. carry the original manufacturers warranties. Britech's policy is to exchange any non-performing product with a similar product or product of equal value during its warranty period as outlined in the terms below. Full product warranties can be obtained from the manufacturer online and/or by request.

Britech will administer and promptly process all warranties in accordance with the manufacturer's specific warranty policies and procedures.

Britech will provide technical assistance to assist the end user or installer in the best method of operation, application and installation.

Custom heating cables carry a twenty (20) year warranty. Warranty on custom TXLP cables is provided by Nexans (refer to their warranty statement summary).

For more information regarding warranty terms or for assistance with your heating cable product please contact Britech Corp. at 1-877-335-7790

Warranty Terms for Heating Cables, Mats & Custom Cable Units:

BRITECH Terms of Limited Warranty (Summary):
This guarantee applies to the following Britech label products: TECH-MAT™, SNOW-MAT™, SNOW-MELT™ and BRI-THIN™ Cables.

Britech warrants to the original purchaser only, that the product is to be free of any defects in material or workmanship during the first twenty (20) years after the date of purchase under proper and normal use of the system. This guarantee is a material warranty only and does not cover any labor or other installation cost. The warranty does not cover installations made by unauthorized persons or faults caused by incorrect design by others, misuse, damage caused by others, damage in transit, incorrect installation and any other subsequent damage that may occur. Repair and/or replacement will be fully chargeable if damage is result of any of the above reasons.

Britech is under no circumstances liable for any incidental, special, or consequential damages or losses including without limitation the loss or profit arising from any cause whatsoever. To obtain a replacement under this warranty, please send a description of the defect, proof of purchase, and the damaged product, shipping paid to Britech at the address noted below. The warranty is void if there is any payment default and if data is not filled-in on the control card. www.britech.ca

NEXANS Terms of Limited Warranty (Summary):

Nexans Norway warrants the products manufactured by it to be free from defects in material and workmanship from the date the warranty form attached to the product is correctly and completely filled in and for a period of twenty (20) years thereafter, or a period of twenty-one (21) years after the production date, whichever period ends first, under proper and normal use and service. Nexans Norway's responsibility does not include defects caused by material obtained by the buyer or by constructions specified by it. Nexans Norway further warrants that the products will have passed those performance tests, if any, called for in the applicable specifications.

The buyer must give Nexans Norway written notice of any defect within thirty (30) days following the discovery of the defect, and in no event later than two (2) weeks after the expiry of the warranty period.

www.nexans.com

Warranty Terms for Controls, Thermostats & Sensors:

ASE / Automated Systems Engineering Terms of Limited Warranty (Summary):

ASE Products are warranted against defects in workmanship and materials for two (2) years from date of sale. This warranty does not apply to damage resulting from accident, misuse, or alteration nor where connected voltage is more than 5% above the configured operating voltage, nor to equipment improperly installed or wired or maintained in violation of the Owner's Manual. No other written or oral warranty applies. No employee, agent, dealer or other person is authorized to give any warranties on behalf of ASE. The customer shall be responsible for all costs incurred in the removal or reinstallation and shipping of the product for repairs. Within the limitations of this warranty, inoperative units should be returned, freight prepaid, to ASE, and we will repair or replace, at our option, at no charge to you with return freight paid by ASE. It is agreed that such repair or replacement is the exclusive remedy available from ASE and that ASE IS NOT RESPONSIBLE FOR DAMAGES OF ANY KIND, INCLUDING INCIDENTAL AND CONSEQUENTIAL DAMAGE. www.goase.com

BRITECH / HONEYWELL

Terms of Limited Warranty (Summary):

Honeywell warrants its products, excluding battery, to be free from defects in the workmanship or materials, under normal use and service, for a period of three (3) years from the date of manufacture. If at any time during the warranty period the product is determined to be defective or malfunctions, Honeywell shall repair or replace it (at Honeywell's option) through Britech.

If product is defective, return it to the following address: Britech Corp., 17 Pullman Court, Toronto, Ontario M1X 1E4 Toll Free: 1-877-335-7790 • Email: info@britech.ca

This warranty does not cover removal or reinstallation costs. This warranty shall not apply if it is shown by Honeywell that the defect or malfunction was caused by damage which occurred while the product was in the possession of a consumer. Honeywell's sole responsibility shall be to repair or replace the product within the terms stated above.

www.honeywell.com

JOHNSON CONTROLS

Terms of Limited Warranty (Summary):

The Company warrants all products manufactured by it to be free from defects in workmanship or materials under normal use and service. If any part of the product herein described, and sold by the Company proves to be defective in workmanship or material, and if such part is within three (3) years from date of sale, returned to the Company transportation charges prepaid and if the same is found by the Company to be defective in workmanship or material, credit based on current prices will be allowed. The date of sale must be established by a receipt showing the purchase date, seller and product sold. If the date of sale cannot be determined, the warranty shall extend for three (3) years from the date of manufacture. www.jci.com

NEXTRON Terms of Limited Warranty (Summary):

The manufacturer warrants each control that it manufactures to be free from defective material or workmanship for a period of 12 months from date of purchase. Under this warranty, the obligation of the manufacturer is limited to repairing or replacing the defective control at its option, when returned to the manufacturer's factory with shipping charges prepaid. If failure has been caused by misuse, incorrect application or alteration of the control, this warranty will be void. UNLESS SPECIFICALLY PROVIDED FOR IN WRITING IN THIS WARRANTY, EACH CONTROL IS PROVIDED WITHOUT ANY WARRANTY OF ANY KIND EITHER EXPRESSED OR IMPLIED. The user shall be made aware that if the equipment is used in a manner not specified by the manufacturer, the protection provided by the equipment may be impaired. www.nextron.ca

Warranty Terms for BRI-GFI Ground Fault Interrupter:

BRITECH Terms of Limited Warranty (Summary):

Britech warrants the BRI-GFI (Ground Fault Interrupter) is manufactured to be free from defective material or workmanship for a period of 12 months from date of purchase. Under this warranty, the obligation of Britech is limited to repairing or replacing the defective control at its option, when returned to the manufacturer's factory with shipping charges prepaid. If failure has been caused by misuse, incorrect application or alteration of the control, this warranty will be void. BRITECH IS UNDER NO CIRCUMSTANCES RESPONSIBLE FOR DAMAGES OF ANY KIND, INCLUDING INCIDENTAL AND CONSEQUENTIAL DAMAGES. This guarantee is a material warranty for components only and does not cover any labor. To obtain a replacement under this warranty, please send a description of the defect, proof of purchase, and the damaged product, shipping paid to Britech at the address noted herein.

Warranty Terms for Self-Regulating Cables (FT-FREEZE TRACE/ST-SMART TRACE)

BRITECH Terms of Limited Warranty (Summary):

This guarantee applies to Britech's Self-Regulating Cables: FT/PT (5) five years / ST (2) two years

Britech warrants to the original purchaser only, that the product is to be free of any defects in material or workmanship (during warranty term as noted above) after the date of purchase under proper and normal use of the system. This guarantee is a material warranty only and does not cover any labor or other installation cost. The warranty does not cover installations made by unauthorized persons or faults caused by incorrect design by others, misuse, damage caused by others, damage in transit, incorrect installation and any other subsequent damage that may occur. Repair and/or replacement will be fully chargeable if damage is result of any of the above reasons.

Britech is under no circumstances liable for any incidental, special, or consequential damages or losses including without limitation the loss or profit arising from any cause whatsoever. To obtain a replacement under this warranty, please send a description of the defect, proof of purchase, and the damaged product, shipping paid to Britech at the address noted herein. The warranty is void if there is any payment default and if data is not filled-in on the control card. www.britech.ca